

# IM-15 GEARMOTORS

DC Permanent Magnet Planetary Gearmotors

E-2430

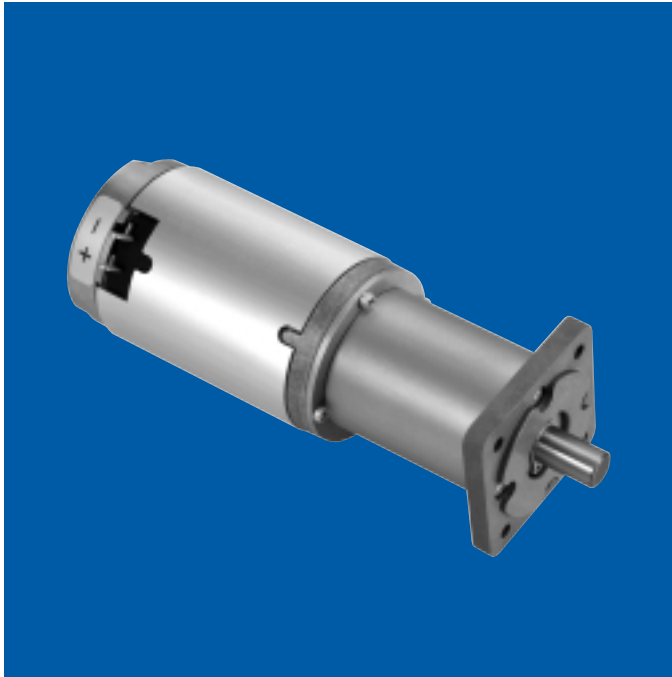

torque rating: Up to 1,250 oz. in.

weight: 14 to 21 ounces depending on ratio and motor

gears: Precision manufactured and heat treated for reliable performance and long life

shaft: Precision-ground No. 416 nitrided stainless steel.

Options: length, smaller diameter, flats, pinions, gears, holes (through or tapped), threaded ends and tapers. Shaft material may change depending upon options selected

backlash: Varies with ratio but average backlash is 3°

gear inertia:  $1.2 \times 10^{-5}$  oz. in. sec.<sup>2</sup> @ input max

bearings: Motor output shaft is supported by life-lubricated sleeve bearings (ball bearing option available); gear train output shaft is supported by life-lubricated sleeve bearing

cables/leads: 8" min. #20 AWG 2 leads UL style 1180

cover: Steel housing, zinc plate

mounting flange: Die-cast zinc

options available:

- EMI suppression
- Terminals

## Dimensions

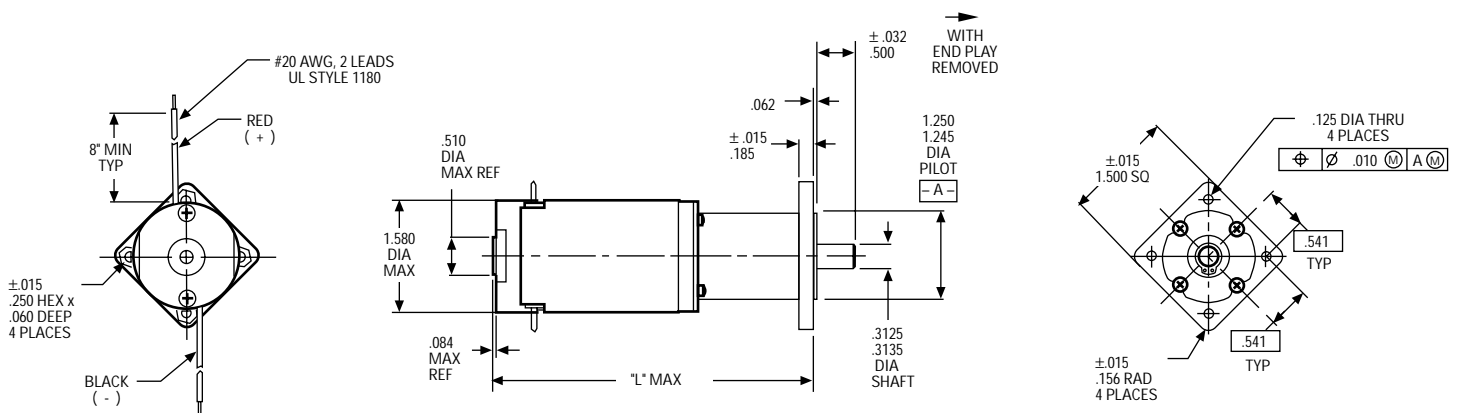

ROTATION (VIEWED FROM SHAFT END)

CW - POSITIVE VOLTAGE TO RED (+), NEGATIVE VOLTAGE TO BLACK (-)

CCW - REVERSE POLARITY

**NOTE:** Consult factory prior to preparing spec control prints. Dimensions are for reference only

## Standard Part Numbers and Data

		SHORT STACK MOTOR			LONG STACK MOTOR		
RATIO	TORQUE MULTIPLIER	STANDARD PART NUMBER PREFIX*	MAX CONTINUOUS TORQUE (oz. in.)	"L" MAX (in.)	STANDARD PART NUMBER PREFIX*	MAX CONTINUOUS TORQUE (oz. in.)	"L" MAX (in.)
4	3.0	409A6012	10	3.717	409A6178	13	3.996
5	3.8	409A6013	13	3.717	409A6179	17	3.996
6	4.5	409A6014	16	3.717	409A6180	20	3.996
16	10.0	409A6015	35	3.956	409A6181	45	4.235
20	13.0	409A6016	45	3.956	409A6182	58	4.235
24	15.0	409A6017	52	3.956	409A6183	68	4.235
25	16.0	409A6018	56	3.956	409A6184	72	4.235
30	19.0	409A6019	66	3.956	409A6185	86	4.235
36	23.0	409A6020	80	3.956	409A6186	102	4.235
64	33.0	409A6021	105	4.189	409A6187	115	4.468
80	41.0	409A6022	143	4.189	409A6188	150	4.468
96	49.0	409A6023	171	4.189	409A6189	185	4.468
100	51.0	409A6024	178	4.189	409A6190	220	4.468
120	61.0	409A6025	213	4.189	409A6191	230	4.468
125	64.0	409A6026	224	4.189	409A6192	275	4.468
144	74.0	409A6027	259	4.189	409A6193	290	4.468
150	77.0	409A6028	269	4.189	409A6194	335	4.468
180	92.0	409A6029	322	4.189	409A6195	345	4.468
216	110.0	409A6030	385	4.189	409A6196	415	4.468
256	105.0	409A6031	367	4.422	409A6197	495	4.701
320	130.0	409A6032	455	4.422	409A6198	475	4.701
384	157.0	409A6033	549	4.422	409A6199	585	4.701
400	164.0	409A6034	574	4.422	409A6200	705	4.701
480	197.0	409A6035	689	4.422	409A6201	740	4.701
500	205.0	409A6036	717	4.422	409A6202	885	4.701
576	235.0	409A6037	822	4.422	409A6203	925	4.701
600	246.0	409A6038	861	4.422	409A6204	1,050	4.701
625	256.0	409A6039	896	4.422	409A6205	1,110	4.701
720	295.0	409A6040	1,032	4.422	409A6206	1,150	4.701
750	306.0	409A6041	1,071	4.422	409A6207	1,250	4.701
864	352.0	409A6042	1,230	4.422	409A6208	1,250	4.701
900	370.0	409A6043	1,250	4.422	409A6209	1,250	4.701
1,024	334.0	409A6044	1,169	4.655	409A6210	1,250	4.934
1,080	442.0	409A6045	1,250	4.422	409A6211	1,250	4.701
1,280	416.0	409A6046	1,250	4.655	409A6212	1,250	4.934
1,296	530.0	409A6047	1,250	4.422	409A6213	1,250	4.701
1,536	500.0	409A6048	1,250	4.655	409A6214	1,250	4.934
1,600	522.0	409A6049	1,250	4.655	409A6215	1,250	4.934
1,920	625.0	409A6050	1,250	4.655	409A6216	1,250	4.934
2,000	652.0	409A6051	1,250	4.655	409A6217	1,250	4.934
2,304	750.0	409A6052	1,250	4.655	409A6218	1,250	4.934
2,400	780.0	409A6053	1,250	4.655	409A6219	1,250	4.934

**NOTE:** Standard part numbers and data continued on page 30

# IM-15 GEARMOTORS

DC Permanent Magnet Planetary Gearmotors

E-2430

## Standard Part Numbers and Data

RATIO	TORQUE MULTIPLIER	SHORT STACK MOTOR			LONG STACK MOTOR		
		STANDARD PART NUMBER PREFIX*	MAX CONTINUOUS TORQUE (oz. in.)	"L" MAX (in.)	STANDARD PART NUMBER PREFIX*	MAX CONTINUOUS TORQUE (oz. in.)	"L" MAX (in.)
2,500	815.0	409A6054	1,250	4.655	409A6220	1,250	4.934
2,880	940.0	409A6055	1,250	4.655	409A6221	1,250	4.934
3,000	980.0	409A6056	1,250	4.655	409A6222	1,250	4.934
3,125	1,020	409A6057	1,250	4.655	409A6223	1,250	4.934
3,456	1,130	409A6058	1,250	4.655	409A6224	1,250	4.934
3,600	1,170	409A6059	1,250	4.655	409A6225	1,250	4.934
3,750	1,220	409A6060	1,250	4.655	409A6226	1,250	4.934
4,096	1,070	409A6061	1,250	4.888	409A6227	1,250	5.167
4,320	1,410	409A6062	1,250	4.655	409A6228	1,250	4.934
4,500	1,470	409A6063	1,250	4.655	409A6229	1,250	4.934
5,120	1,340	409A6064	1,250	4.888	409A6230	1,250	5.167
5,184	1,690	409A6065	1,250	4.655	409A6231	1,250	4.934
5,400	1,760	409A6066	1,250	4.655	409A6232	1,250	4.934
6,144	1,610	409A6067	1,250	4.888	409A6233	1,250	5.167
6,400	1,680	409A6068	1,250	4.888	409A6234	1,250	5.167
6,480	2,110	409A6069	1,250	4.655	409A6235	1,250	4.938
7,680	2,010	409A6070	1,250	4.888	409A6236	1,250	5.167
7,776	2,530	409A6071	1,250	4.655	409A6237	1,250	4.938
8,000	2,100	409A6072	1,250	4.888	409A6238	1,250	5.167
9,216	2,390	409A6073	1,250	4.888	409A6239	1,250	5.167
9,600	2,520	409A6074	1,250	4.888	409A6240	1,250	5.167
10,000	2,620	409A6075	1,250	4.888	409A6241	1,250	5.167
11,520	3,010	409A6076	1,250	4.888	409A6242	1,250	5.167
12,000	3,140	409A6077	1,250	4.888	409A6243	1,250	5.167
12,500	3,280	409A6078	1,250	4.888	409A6244	1,250	5.167
13,824	3,620	409A6079	1,250	4.888	409A6245	1,250	5.167
14,400	3,780	409A6080	1,250	4.888	409A6246	1,250	5.167
15,000	3,940	409A6081	1,250	4.888	409A6247	1,250	5.167
15,625	4,100	409A6082	1,250	4.888	409A6248	1,250	5.167
17,280	4,520	409A6083	1,250	4.888	409A6249	1,250	5.167
18,000	4,710	409A6084	1,250	4.888	409A6250	1,250	5.167
18,750	4,910	409A6085	1,250	4.888	409A6251	1,250	5.167
20,736	5,430	409A6086	1,250	4.888	409A6252	1,250	5.167
21,600	5,660	409A6087	1,250	4.888	409A6253	1,250	5.167
22,500	5,900	409A6088	1,250	4.888	409A6254	1,250	5.167
25,920	6,790	409A6089	1,250	4.888	409A6255	1,250	5.167
27,000	7,070	409A6090	1,250	4.888	409A6256	1,250	5.167
31,104	8,150	409A6091	1,250	4.888	409A6257	1,250	5.167
32,400	8,500	409A6092	1,250	4.888	409A6258	1,250	5.167
38,880	10,200	409A6093	1,250	4.888	409A6259	1,250	5.167
46,656	12,200	409A6094	1,250	4.888	409A6260	1,250	5.167

Maximum continuous rated torque values are based upon motor temperature rise considerations. Starting or impact loads greater than 10 times the rated maximum continuous torque (1,500 oz. in. maximum) could result in gear or shaft damage

### \*When You Order

Each of the basic motor armature windings (see chart, next page) can be used with any of the gear ratios listed in the two preceding charts. To order, state the gear train standard part number prefix, plus a motor armature winding dash number. EXAMPLE: 409A6186-3 is a 36:1 IM-15 long stack gear train with a "-3" armature winding, 24 volts, 5,200 rpm, 5.0 oz. in. torque, etc.

## Basic Motor Data

ARMATURE WINDING DASH NO.*	VOLTAGE (VDC)	SPEED $\pm 10\%$ NO LOAD (rpm)	CURRENT NO LOAD (max amps)	RATED TORQUE (oz. in.)	CURRENT AT RATED TORQUE (max amps)	TORQUE CONSTANT (oz. in./amps)	RESISTANCE (ohms)
<b>Short Stack — Motors</b>							
-2	12	5,200	.29	4.0	2.0	2.95	2.25
-3	24	5,200	.14	4.0	1.0	6.00	9.00
<b>Long Stack — Motors</b>							
-2	12	5,200	.35	5.0	2.3	3.00	2.00
-3	24	5,200	.17	5.0	1.2	6.10	6.60

### \*When You Order

Each of the basic motor armature windings (see chart, next page) can be used with any of the gear ratios listed in the two preceding charts. To order, state the gear train standard part number prefix, plus a motor armature winding dash number. EXAMPLE: 409A6186-3 is a 36:1 IM-15 long stack gear train with a "-3" armature winding, 24 volts, 5,200 rpm, 5.0 oz. in. torque, etc.

## Typical Motor Performance

### Short Stack Motors

Part Nos.: 409A6012 thru 6094

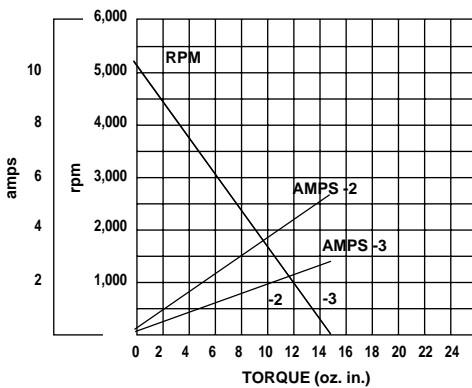

### Long Stack Motors

Part Nos.: 409A6178 thru 6260

